

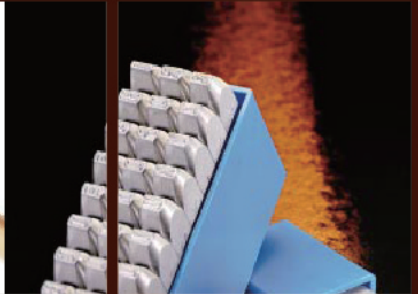

通宝兆业有限公司

TUNG PO INTERNATIONAL LIMITED

地址：香港弥敦道 563 号交通银行大厦 6 楼全层
电话：(852) 2543 3798 传真：(852) 2369 9681
电邮：sales@tphholdings.com, tpil@biznetvigator.com

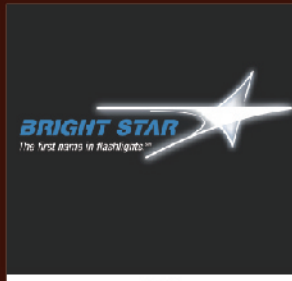

BMI

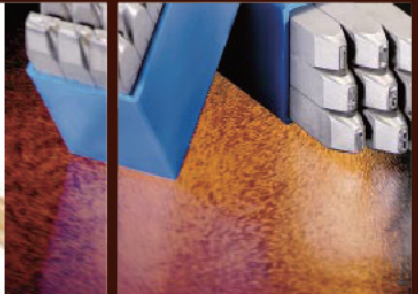

ハードな作業用

耐久テスト
随時実施

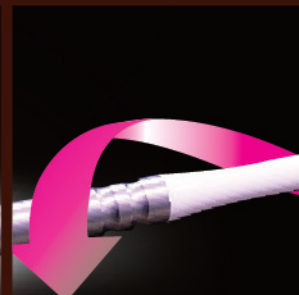
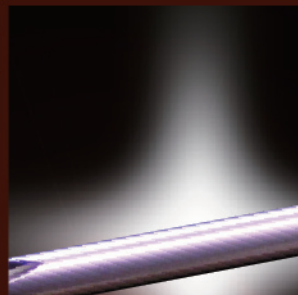

目錄 CONTENT

日本

新龜牌	SUNFLAG	螺絲刀系列	1-7
旭日牌	ASAHI	扳手工具系列	8-10
大見M嘜	OMI	開孔器系列	11-12
小霸王	SUPER	尖尾扳手工具系列	13
百利	EIGHT FLAG	六角匙系列	16
		螺絲刀系列	29

德國

凱尼派克	KNIPEX	德國專業工具	17-19
	WERA	德國專業工具	17-19
獵人牌	HUNTER	工具系列	22-23
	BOHLE	玻璃吸盤系列	21
	BMI	油缸尺及量具系列	21
高倫	KULLEN	鋼絲轆系列	20

美國

紅星牌	BRIGHTSTAR	安全電筒系列	24-25
超級絞盤	SUPERWINCH	專業絞盤系列	29
	DISSTON	開孔器系列	26

奧地利

魚嘜	FISCH	平底鑽及鑽咀系列	29
----	-------	----------	----

丹麥

維京	VIKING	鋸條／鋸片系列	29
----	--------	---------	----

以色列

嘉寶牌	KAPRO	水平尺系列	27-28
-----	-------	-------	-------

衝撃吸収 高耐久 One Side Bit

SUNFLAG®
MADE IN JAPAN

段付トーシヨンシリーズ

高トルク打撃回転での衝撃を
トーシヨン部のねじれで吸収

14.4・18V H級 磁力付
IMPACT

TORSION HARD BIT



120mmロングサイズ登場!
(インパクト最短ボディーに対応)

- 芯ブレ精度が高く、スムーズなトルク伝達で打込みバランスが安定!
- 表面が硬く内部に靱性があり、ネジ溝の破損を防ぐ効果があります。

なつとくの
長寿命達成!



精密形状加工/特殊熱処理済

ハードな作業用

耐久テスト
随時実施



ネジ頭が見易く
確実にキャッチ
カケに強い高耐久

陳列台紙ディスプレイ



280×445

2本組



5本組



コーススレッド/スレンダービス/ドリルネジ/タッピングビス
Cチャン・アルミ・鉄板・木

スーパースリムトーシヨンビット

No. BXB	2本組	2Pcs. Blister Pack			
No.	SIZE x L	定価 (円)	内箱/外箱	陳列台紙 明細	4906842
BXB-1065	Φ1×65mm	OPEN	10/100	2個	155×35 111392
BXB-1100	Φ1×100mm	OPEN	10/100	2個	155×35 111408
BXB-2065	Φ2×65mm	OPEN	10/100	2個	155×35 111415
BXB-2085	Φ2×85mm	OPEN	10/100	2個	155×35 111422
BXB-2110	Φ2×100mm	OPEN	10/100	4個	155×35 111439
BXB-2120	Φ2×120mm	OPEN	10/100	2個	155×35 111446

No. BXB	5本組	5Pcs. Blister Pack			
No.	SIZE x L	定価 (円)	内箱/外箱	陳列台紙 明細	4906842
BXB-52065	Φ2×65mm	OPEN	10/100	2個	155×65 111460
BXB-52085	Φ2×85mm	OPEN	10/100	2個	155×65 111477
BXB-52100	Φ2×100mm	OPEN	10/100	2個	155×65 111484
BXB-52120	Φ2×120mm	OPEN	10/100	2個	155×65 111491

※陳列ディスプレイは数量に限りがありますのでご了承ください。



800 优质手感加硬螺丝刀

型号	产品明细	包装
#1x75	优质手感加硬螺丝刀 (+)	6/120
#2x100	优质手感加硬螺丝刀 (+)	6/120
#2x150	优质手感加硬螺丝刀 (+)	6/60
#3x150	优质手感加硬螺丝刀 (+)	6/60
5.5x75	优质手感加硬螺丝刀 (-)	6/120
6.0x100	优质手感加硬螺丝刀 (-)	6/120
6.0x150	优质手感加硬螺丝刀 (-)	6/60
8.0x150	优质手感加硬螺丝刀 (-)	6/60



333 传统日式加硬螺丝刀

型号	产品明细	包装
#2x100	日式加硬螺丝刀 (+)	20/120
#2x150	日式加硬螺丝刀 (+)	12/120
#2x300	日式加硬螺丝刀 (+)	12/120
6.0x100	日式加硬螺丝刀 (-)	20/120
6.0x150	日式加硬螺丝刀 (-)	12/120
6.0x300	日式加硬螺丝刀 (-)	12/120



666 高纤加硬螺丝刀

型号	产品明细	包装
#1x75	高纤加硬螺丝刀 (+)	6/60
#2x100	高纤加硬螺丝刀 (+)	6/120
#2x150	高纤加硬螺丝刀 (+)	6/120
#3x150	高纤加硬螺丝刀 (+)	6/60
5.5x75	高纤加硬螺丝刀 (-)	6/60
6.0x100	高纤加硬螺丝刀 (-)	6/120
6.0x150	高纤加硬螺丝刀 (-)	6/120
8.0x150	高纤加硬螺丝刀 (-)	6/60



666 高纤电脑批

型号	产品明细	包装
#00x75	高纤电脑批 (+)	6/240
#00x100	高纤电脑批 (+)	6/240
#0x75	高纤电脑批 (+)	6/120
#0x100	高纤电脑批 (+)	6/120
#0x150	高纤电脑批 (+)	6/60
3.0x75	高纤电脑批 (-)	6/240
3.0x100	高纤电脑批 (-)	6/240
4.0x75	高纤电脑批 (-)	6/120
4.0x100	高纤电脑批 (-)	6/120
4.0x150	高纤电脑批 (-)	6/60

776/777 棘轮活动曲批系列

型号	产品明细	包装
776B	超薄棘轮活动曲批 (蓝色)	6/60
776Y	超薄棘轮活动曲批 (黄色)	6/60
776R	超薄棘轮活动曲批 (红色)	6/60
777	棘轮活动曲批 (黑色)	6/60
777-WH8	棘轮活动曲批 连批头	6/60
770	棘轮特殊曲批 连批头	6/60
777-TX	棘轮活动曲批 连星批头	6/60





61/72/176 精密轻巧电脑批

型号	产品明细	包装
61	精密轻巧电脑批 (+) #00	12/120
62	精密轻巧电脑批 (+) #00	12/120
63	精密轻巧电脑批 (+) #1	12/120
64	精密轻巧电脑批 (-) 1.2	12/120
65	精密轻巧电脑批 (-) 1.8	12/120
66	精密轻巧电脑批 (-) 2.5	12/120
67	精密轻巧电脑批 (-) 3.0	12/120
72	精密轻巧电脑批 六角 1.27	12/120
73	精密轻巧电脑批 六角 1.5	12/120
74	精密轻巧电脑批 六角 2.0	12/120
75	精密轻巧电脑批 六角 2.5	12/120

7350/7380 试电笔系列

型号	产品明细	包装
7380NL	试电笔 (低电压用)	12/240
7380NH	试电笔 (高电压用)	12/240
7380NV	汽车试电笔 (6-24伏用)	12/240
7350	功能试电笔 (100V-200V)	12/240



9000/9100 特殊拾取工具

型号	产品明细	包装
9000-350	活动拾取工具 350mm (抓)	6/60
9000-500	活动拾取工具 500mm (抓)	6/60
9100	活动拾取工具 600mm (抓+磁)	6/60
9750	活动拾取工具 600mm (磁)	6/60
201	迷你拾取工具 115mm (抓)	12/120

96/98/99/670 短小迷你螺丝刀

型号	产品明细	包装
96B	大头短小螺丝刀 (黄色)	6/120
98B	双头短小螺丝刀 (红/绿色)	6/240
99B	双头极短螺丝刀 (红色)	6/240
670	高纤短小螺丝刀 (蓝色)	6/60

No.6800 ハイグリップドライバー(強力貫通タイプ) High-Grip Screwdriver, Tang-through for hard duty type



No.98/98-B ミニスタ 2WAY 2-Way Mini Stubby Driver

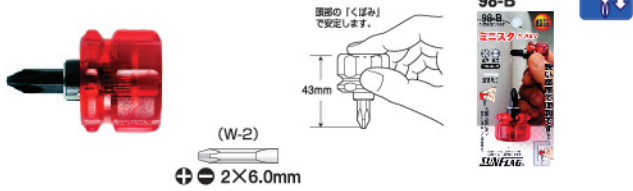

No.1350 ぷちドラ Replaceable Drivers Set

ビットが収納できるので携帯、保管に便利！



No.5800/5812 テクニカルドライバー Telescopic Driver(3-length)

1本のビットで3段階の長さ調節ができる！

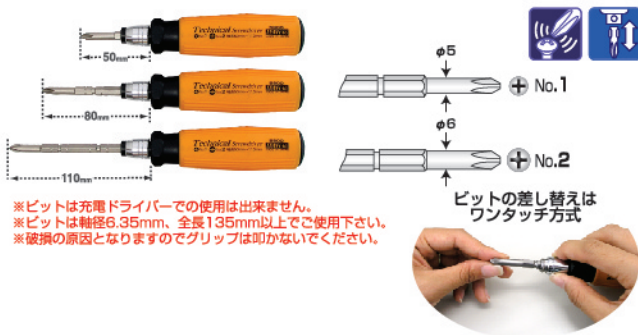

No.7 オフセットドライバー

Combination Offset Driver

狭い箇所など限られたスペースでの作業に！

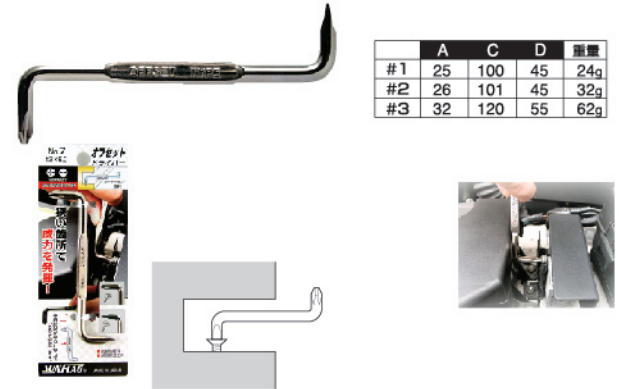

No.15-C/25-C ビスキャッチ Screwholding Driver

小さいねじを確実にキャッチ!!

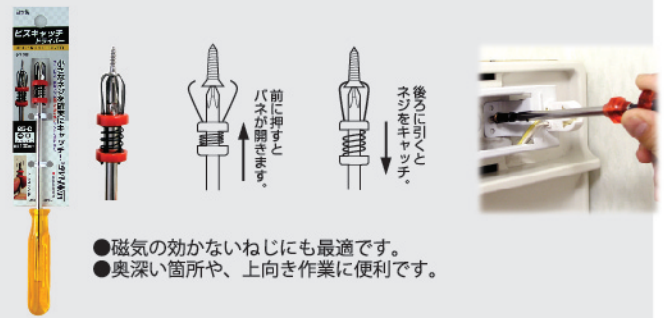

No.96/96-B ポケスタ

4-IN-1 Screw Drivers

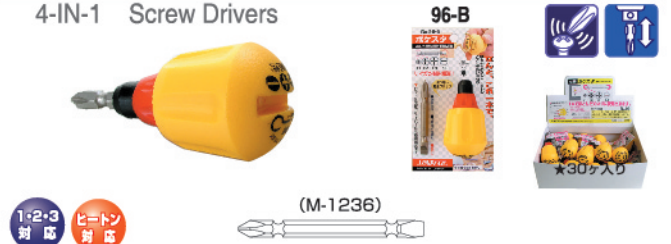

ヒートン
対応

ご家庭のほとんどのねじ、ヒートン、蝶ねじ、ノブ、コック等に使えます。



ヒートンまわし満付き 手を痛めることなく、各種ヒートン類を簡単に廻せます。

No.193-FB/FB-19 フレキシビット付ラチェットドライバー

Ratchet Drivers With Flexible Bit

※フレキシビットはインパクトドライバーで使用しないで下さい、破損の原因となります。



No.1000/1000-B 精密用ラチェット

Precision Ratchet Drivers

精密機器、パソコン、ゲーム機、
メガネなどの極小ねじに！



■ビット明細

⊖	1.5	
	2.0	
	3.0	
	#0	
⊕	#1	#1 bit"/>
	#2	#2 bit"/>



No.XT-1236 薄型レンチ (ビット差替式)

Flat Driver

精密機器・機械の補正メンテナンスに便利です!!



■ビット明細

(SS-1236)

- No.1
- No.2
- No.3

6.0mm



黄色面は磁力があるので
精密部品の採取に便利です。

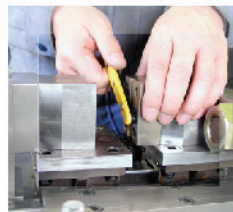
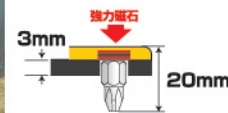

市販の六角ビットも使用できます。

No.9100 W キャッチ

Pick-Up Tools (500mm)

ツメで
キャッチ

マグネットで
キャッチ



用途に応じて不要な場合はマグネット部を
外して下さい。

★1本で2通り使えます。



最大幅
約20mm

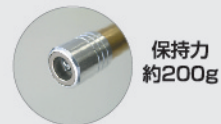

保持力
約200g



No.777-WH8 オフセットラチェットセット(六角)

Offset Ratchet Drivers

■ビット明細

- (両頭ビット) No.1 × 4.5mm [W-1]
- No.2 × 6.0mm [W-2]
- No.3 × 7.0mm [W-3]
- (HEXビット) 2.5mm [SH-25]
- 3.0mm [SH-30]
- 4.0mm [SH-40]
- 5.0mm [SH-50]



No.770/770-B ドライバーレンチ/レンチアダプター

Driver Wrenches

2方向の曲がり力が威力を発揮!!

両サイド使用出来ます。



最大トルク
280kg/cm



メガネレンチで! モンキーレンチで!

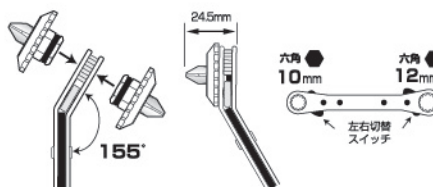

■ビット明細 (770/770-B共通)

レンチアダプター (10mm間)

- No.1 [SS-14]
- No.2 [SS-24]
- No.3 [SS-34]
- 6.0mm [SS-64]
- ソケットアダプター [E-2]



早まわし機能付。

日本制造

No.180/185/188/190 オートポンチ/ ネイルポンチ

Auto Punch

押すだけで強力打ち込み可能!

●オートポンチ/180 Auto Center Punches

刃先: SK材



SK Steel tip
取替用先端チップ/AP-5
材質: SK材 定価: 400円

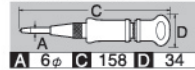

Extra hard steel tip
取替用先端チップ/AP-6
材質: 超硬材 定価: 660円

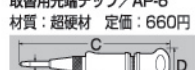

Extra hard steel tip
取替用先端チップ/SP-8
材質: 超硬材 定価: 630円

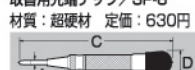

SK Steel tip
取替用先端チップ/AP-7
材質: SK材 定価: 300円

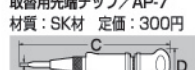

●オートポンチ/185 Auto Center Punches

刃先: 超硬材



●オートポンチS/188 Small Center Punches

刃先: 超硬材



●ネイルポンチ/190 Nail Punches

刃先: SK材



- ハンマー不要、ワンタッチ。 ●打込みの強弱が調節できます。
- 軽い、カケない超硬チップ付、金型製作、精密工作、配電盤、測定用



No.LED-01/02/03 ピカエモン

Led Tool Light

LED-01

LED-02

LED-03



■ 万能クリップで丸軸・六角軸・平形状に取付可能です。 ■ 暗い箇所の作業に!

- ◎ドライバー/六角レンチなどの工具類
- ◎ピンセット/筆記具
- ◎フィッシング・レジャー
- ◎ペットの散歩に!

いろいろな用途でご使用下さい。

高輝度照明



車両メンテ・建築現場・工場内作業に便利です。



電池寿命自然放電により短い場合がありますのでご了承下さい。



LED/NICHIA製
球耐久性: 50,000時間

ボタン電池
連続使用10~20時間

No.GT-2000 車両用メンテナンスキット

The Car Repair-Tool

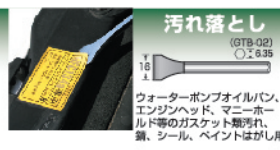
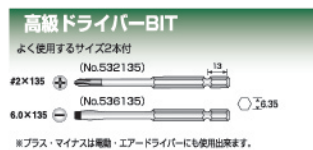

【パーツ関連】

使い方もいろいろ! 車両整備等に。

パーツの保管に便利なホルダー付き



日本制造

No.SP-60 イッパツクン

Point Awl

建築金具の取付けにご使用下さい。



押すだけでセンターに目安の目印が打てます。



ねじ穴に真っすぐ合わせて押す。

ねじ穴許容 約φ3~φ6用

丁番/戸車/キャスター
棚受金具/打掛ダイ
ブラケット/その他



押すと先端からキリが
出ますのでご注意ください。

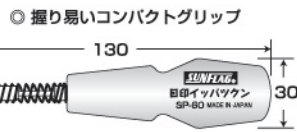

No.TR-310 タップレンチ

Tap Wrench

先端くわえ爪の脱落及び紛失、かみ合わせ時の不整合を解消!



●特殊ハガネ鋼・総焼き入れ

スーパースリムトーションビット 両頭タイプ

Super Slim Torsion Bit (Double End)

先端スリムタイプでねじ頭がとらえやすい!
さらに、トーション効果で衝撃吸収、耐久性 UP!!

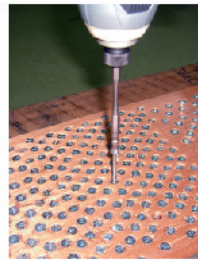

H級 磁力付

タッピングビス/スレンダービス
ドリルビス/スリムビス/一般ビス

No.LG-6100 L グリップスリム PRO 差替タイプ

L Grip bit Extension



「差替タイプ」&「小型ヘッド」で
パワフル・最強スペックで登場。
極小スペースでの作業が、
スムーズに、そしてスピーディに!!

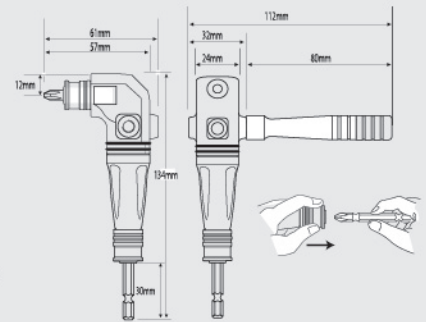

■ビット明細
スリスタビット #2×35 / 1本
片頭ビット #2×55 / 1本

No.SA-2/3/4 ソケットアダプター

Socket Adapters

角度を付けて廻せます。

(SA-2は直進作業のみ)

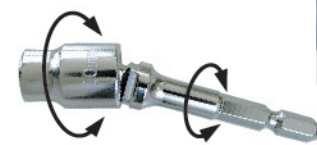

6.35mm

※ソケットは市販品をご使用下さい。
※真っ直ぐの状態でも固定出来ます。

日本制造

Code **CLS060**



Revowave 人工力学设计扳手

型号	产品明细	包装
SLAS6	双开扳手六件套 5.5~24mm	10
SLAS62	双开扳手六件套 8~24mm	10
CLS060	梅开扳手六件套 8~17mm	10
CLS100	梅开扳手十件套 8~24mm	10
CLS140	梅开扳手十四件套 5.5~32mm	10
SL系列	尺寸由 5.5 ~ 24mm	
CL系列	尺寸由 5.5 ~ 32mm	

Code **LSXS6**



LIGHT00L 超轻强硬扳手

型号	产品明细	包装
LSXS6	双开六件套 (袋装) 5.5~24mm	10
LEXS6	双开六件套 (夹装) 5.5~24mm	10
LEFS3	双梅三件套 (卡装) 8~14mm	10
LOFS601	双梅六件套 (盒装) 8~24mm	10
LCWS6	梅开六件套 (袋装) 10~19mm	10
LEWS6	梅开六件套 (夹装) 10~19mm	10
LCWUS30	迷你梅开三件套 8~12mm	10
LSX 系列	尺寸由 5.5 ~ 24mm	
LOF 系列	尺寸由 8 ~ 24mm	
LCW 系列	尺寸由 5.5 ~ 24mm	

Code **CPS/ CPXS**



ASAHI 日本工业用扳手

型号	产品明细	包装
CPS1011M	梅开十一件套 8~24mm	10
CPS1011	梅开十一件套 3/8" ~1"	10
CPS1014M6	梅开十四件套 6~32mm	10
CPS1014M8	梅开十四件套 8~24mm	10
CPS1014M10	梅开十四件套 10~32mm	10
CPS1014	梅开十四件套 3/8" ~1.1/4"	10
CP系列	尺寸由 6 ~ 60mm	

Code **RING SPANNER**



日本制造

Code **DVS0910**



Code **AQS0710**

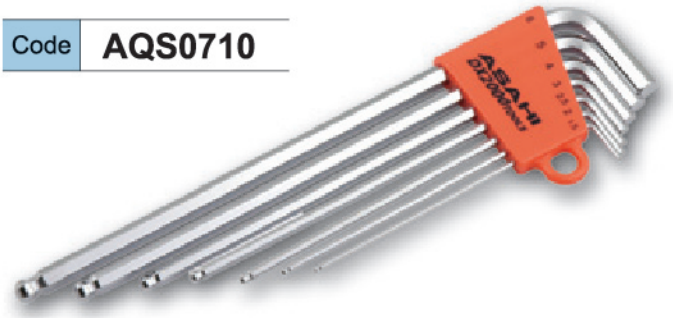

DX2000 钢珠内六角扳手系列

型号	产品明细	包装
DVS0910	钢珠加长短颈波头六角扳手 (9 件套)	5
DWS0910	钢珠标准短颈波头六角扳手 (9 件套)	5
AQKS0910	钢珠加长波头六角扳手 (9 件套)	5
AQKS0710	钢珠加长波头六角扳手 (7 件套)	5
AYKS0910	钢珠加长六角扳手 (9 件套)	5
AZKS0910	钢珠标准长波头六角扳手 (9 件套)	5
APTS0710	钢珠加长波头六角扳手 (7 件套) 黑身	5

DX2000 工业用六角扳手系列

型号	产品明细	包装
AQS0910	加长波颈内六角扳手 (9 件套)	5
AQS0710	加长波颈内六角扳手 (7 件套)	10
AYS0910	加长内六角扳手 (9 件套)	5
AYS0710	加长内六角扳手 (7 件套)	10
AZS0910	标准波颈内六角扳手 (9 件套)	5
AZS0710	标准波颈内六角扳手 (7 件套)	10
AXS0910	标准长内六角扳手 (9 件套)	5
AXS0710	标准长内六角扳手 (7 件套)	10

Code **DYS0910**



DX2000 特殊用途内六角扳手

型号	产品明细	包装
DYS0910	加长双曲头 30 度六角扳手 (9 件套)	5
DZS0910	标准长双曲头 30 度六角扳手 (9 件套)	5
ATXS0710	星型内六角扳手 (7 件套)	5
AQUS0910	彩色加长波头六角扳手 (9 件套)	5



日本制造

Code **SD2340M**



ASAHI 汽车专用套筒套装

型号	产品明细	包装
2340M	1/4" 头公制 4~13mm 套装 (34 件)	10
4240M	1/2" 头公制 10~32mm 套装 (24 件)	4
4240	1/2" 头英制 3/8"~1. 1/4" 套装 (24 件)	4
4150M	1/2" 头公制 10~27mm 套装 (15 件)	4
4150	1/2" 头英制 3/8"~1" 套装 (24 件)	

Code **VR0319**



Code **LVR4250**



ASAHI 汽车套筒工具

型号	产品明细	包装
VR0319	3/8" 正反棘齿扳手 (啦啦柄)	10
VR0400	1/2" 正反棘齿扳手 (啦啦柄)	10
VR0650	3/4" 正反棘齿扳手 (啦啦柄)	10
LVR3110	3/8" 正反棘齿扳手 LIGHTOOL	10
LVR3115	3/8" 正反棘齿扳手 LIGHTOOL	10
LVR3170	3/8" 正反棘齿扳手 LIGHTOOL	10
LVR3175	3/8" 正反棘齿扳手 LIGHTOOL	10
LVR4250	1/2" 正反棘齿扳手 LIGHTOOL	10

Code **VX4000**



ASAHI 汽车特殊用途套装工具

型号	产品明细	包装
VX4000	1/2" 头六角套筒扳手 (12 件套)	4
VCS3130	特殊吊索型扳手 (13 件套)	4
LCS2000	扭力扳手运替换梗头 (9 件套)	1
LCS3000	扭力扳手运替换梗头 (9 件套)	
LCS4000	扭力扳手运替换梗头 (9 件套)	

日本制造

日本 OMI 奥美 多功能手提磁力钻

Compact Portable Magnetic Drill
FLATTER Series
Ideal for field work



MGF-50AH

专业型 (直径 ϕ 50mm)

重 15KG

新产品
MGF-30AH



轻巧型 (直径 ϕ 30mm)

仅重 8.8KG

前后左右四方位调校功能

切割能力

有效切割深度 35mm

前/后

调整范围 10mm

左/右

调整范围 20mm

暗黑位置工作



内置 LED，有助于黑暗地方工作。

垂直使用



不论高空或垂直工作，均能操作自如。

倒置操作

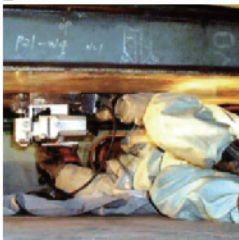

适用于狭窄环境及倒置使用工作。

高速锋利切割



采用原厂 OMI 专利开孔器，可提供高达 680min 转速，功能卓越。

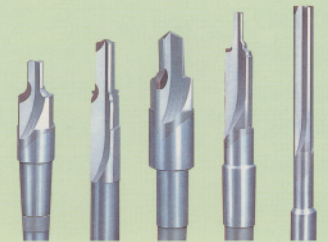

Drilling Reaming Tools



大见工业株式会社

OMI KOGYO CO., LTD.

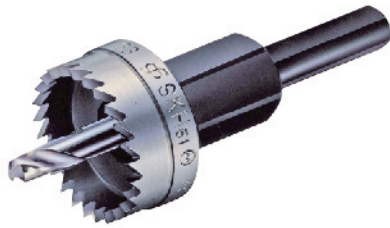

E型 - HSS锋钢开孔器

型号	产品明细	包装
E12-36	锋钢开孔器 (每一毫米计算)	12
E37-55	锋钢开孔器 (每一毫米计算)	6
E56-100	锋钢开孔器 (每一毫米计算)	1

被削材：铁板

有效切削能力：1.6mm



TG型 - TCT钻石钢开孔器

型号	产品明细	包装
TG15-35	钻石钢开孔器 (每一毫米计算)	5
TG36-TG55	钻石钢开孔器 (每一毫米计算)	3
TG56-TG100	钻石钢开孔器 (每一毫米计算)	1

被削材：铁板、不锈钢板、铸铁、铜、铝
FRP、合成树脂

有效切削能力：5.0mm



SL型 - HSS+ Co锋钢开孔器

型号	产品明细	包装
SL12-39	锋钢开孔器 (每一毫米计算)	5
SL40-59	锋钢开孔器 (每一毫米计算)	3
SL60-150	锋钢开孔器 (每一毫米计算)	1

被削材：铁板、钢管、铸铁、铜、铝、FRP
合成树脂、盐水管、木板、石膏板

有效切削能力：3.2mm

被削材：不锈钢板 (1.0mm 或以下)



深穴钻石钢长开孔器

型号	产品明细	包装
35SQ17.5	深穴钻石钢长开孔器 (每 0.5mm 计算)	5
35SQ28	深穴钻石钢长开孔器 (每 1.0 mm计算) 最大深度为 35mm 直径尺寸最大为35mm	5
50SQ17.5	深穴钻石钢长开孔器 (每 0.5mm 计算)	5
35SQ28	深穴钻石钢长开孔器 (每 1.0mm 计算) 最大深度为 50mm 直径尺寸最大为80mm	5



深穴开孔磁座钻

型号	产品明细	包装
MGF30AH	轻巧型磁力钻 (自由方向) 最大深度为 35mm 直径尺寸最大为 30mm	1
MGF50AH	重型磁力钻 最大深度为 50mm 直径尺寸最大为 50mm	1

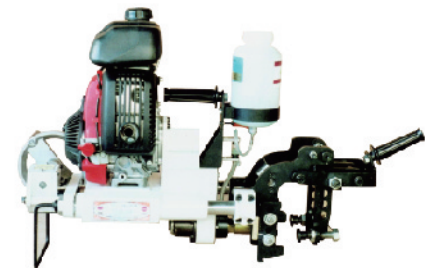

路轨专业切割及开孔机器

型号	产品明细	包装
NTM-405	引擎式轨道切断机 直径：405mm	1
NTM-32	引擎式轨道开孔机	1



PIPE WELDING CLAMP

配管の固定・芯出しワンタッチでOK!
だれでも簡単に施工OK!

PIPE WELDING CLAMPS "Bridge"

パイプ溶接用 外面クランプ“ブリッジ”

NEW 新製品

配管接触部にステンレス材使用!



WELDING CLAMPS Multi type

溶接用 マルチクランプ PAT.P

NEW 新製品

アダプタをつけ替えて
あらゆるクランプ作業OK!



SUPER TOOL



萬國五金行 INTERNATIONAL COMPANY

通寶興達集團有限公司 直屬機構

香港九龍彌敦道 563 號交通銀行大廈 6 字樓

6/F., Bank of Comm. Bldg., 563 Nathan Rd., Yau Ma Tei

TEL: 27230219 FAX: 23699681 E-mail: intco@tphtholdings.com



**衷心感謝下列公司多年全力支持，
我們再接再勵提供更優質服務。**

- | | |
|---------------|--|
| - 中華電力有限公司 | CLP Power Hong Kong Limited |
| - 香港鐵路有限公司 | MTR Corporation Limited |
| - 香港特別行政區政府 | The Gov. of the H.K. Special Admin. Region |
| - 醫院管理局 | The Hospital Authority |
| - 香港海洋公園 | Ocean Park Corporation |
| - 林德港氧有限公司 | Linde HKO Limited |
| - 昂坪 360 有限公司 | Ngong Ping 360 Limited |
| - 香港迪士尼樂園 | Hong Kong Disneyland Park |
| - 香港電燈有限公司 | The Hongkong Electric Company Limited |
| - 香港中華煤氣有限公司 | The H.K. and China Gas Company Limited |
| - 香港飛機工程有限公司 | H.K. Aircraft Engineering Company Limited |

主席	李桂蔭
董事	梁成熙 鄭嘉煌
營業部	周麗娟 劉樹仁 鍾華好

致意

專營物料供應，環球配件、工具、設備採購

香港區代理:



歷屆展覽場館相片



2014年上海



2013年上海



2009年上海



2010年上海

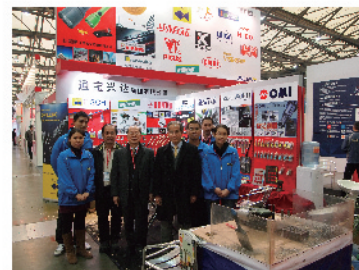

2011年上海



2012年上海



2005年北京



2006年北京



2007年青島



2008年上海

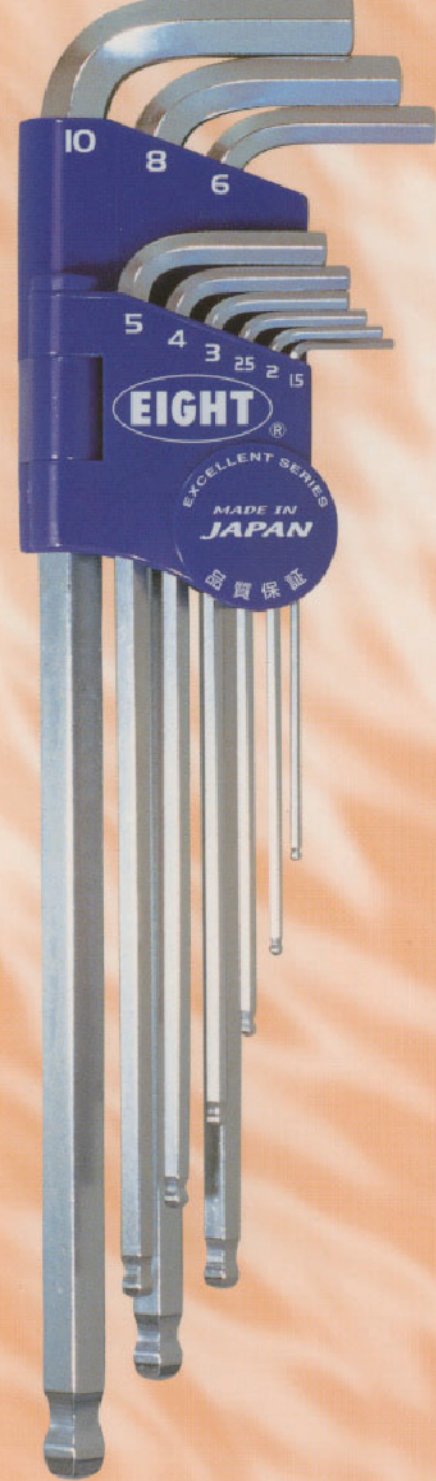

EIGHT



フィットリングが
確実にボルトを
キャッチします。

日本捌牌独自研制出高品质特殊合金钢，耐磨性极佳，扭转力达到世界级标准。
在生产六角匙其间，对其边、角精确度极之严格，精度达到日本工业标准上级水平。
经【洛氏硬度】标准评鉴，等级高达 56 至 61 度，不论硬度或扭动力完全乎合世界一级水平。
日本捌牌优质六角匙，品质及技术的结晶。



Wera
The Best Tools For The Job

德国专业工具

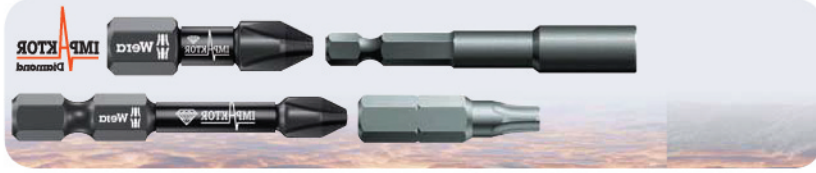

Pliers black
atramentized,
head polished



Head polished,
handles plastic
coated



Head polished,
handles with multi-
component grips

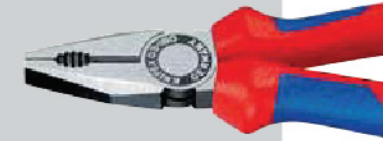

Pliers chrome plated,
handles plastic
coated



Pliers chrome plated

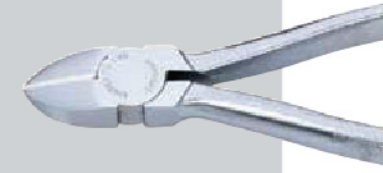

Pliers chrome plated,
handles with multi-
component grips

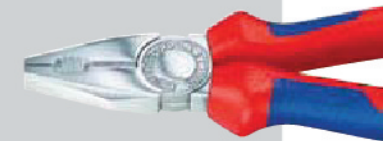

Pliers chrome plated,
handles insulated with
multi-component grips,
VDE-tested
DIN EN/IEC 60900

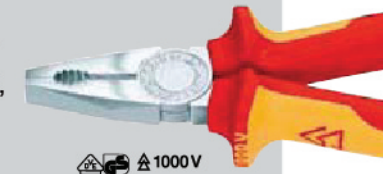

Pliers chrome plated,
handles with dipped
insulation, VDE-tested
DIN EN/IEC 60900

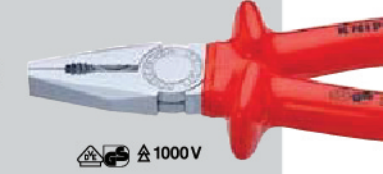

原裝德國進口

L-Keys for Hexagon Socket Screws



12-piece screwdriver set



3160 i/7 Screwdriver set, stainless and rack



Tool-Check PLUS



1735 Screwdriver for slotted screws



Kraftform Kompakt



原裝德國進口

德国专业工具

KNIPEX Alligator® Water Pump Pliers

DIN ISO 8976



88 01 180
 



88 01 250
 



88 02 250
 



88 05 250
 



88 06 250
   



88 07 250
   

Pipe Gripping Pliers

for tube fittings and connectors

DIN ISO 5743



81 13 230



Cobra® QuickSet Hightech Water Pump Pliers



Press the button – open pliers completely



Position jaw – simply slide and close pliers

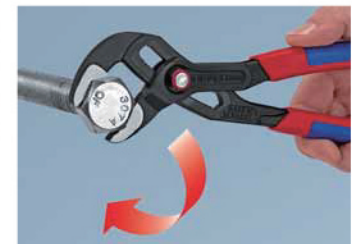

Hinge bolt locks itself with the first workload

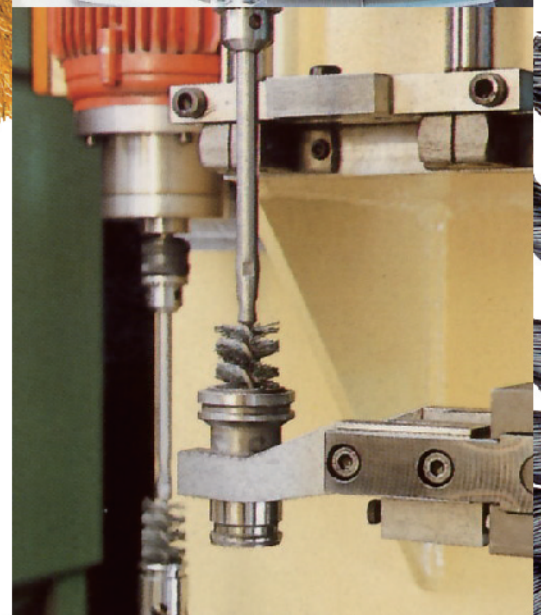

高品质钢丝，柔硬度适中，能做出良好打磨效果，耐用程度极佳。产品种类繁多，扁型钢丝轱、有柄钢丝轱、杯型钢丝轱，并配合不同类型钢丝，如波纹，扭曲，直身等钢丝，拥有最大钢丝轮尺寸范围，完全全能满足您的需求。



BASIC FRAME SERIES 传统油缸尺

Ultrasonic welded high-impact plastic frame, Ergonomically shaped frame with easy-to-grip, soft rubber protrusions, with slide rings instead of ball bearings.

强化纤维框架，设计依照人体学原理，加上软胶易于舒适紧握。使用滑轮环方式代替一般球轴承。

We deliver long-length tapes with STANDARD V-frame



BMI



STANDARD FRAME SERIES 一般油缸尺

Ultrasonic welded high-impact plastic frame, Ergonomically shaped frame with easy-to-grip, with plastic slide rings instead of ball bearings.

一般金属框架，设计依照人体学原理，易于紧握。使用塑胶滑轮环方式代替一般球轴承。

WEISS[®]
G E R M A N Y



Veribor blue line Suction Lifter, 3-Cup



Veribor/ Jobo 专业玻璃吸盘



Veribor blue line Suction Lifter, 1-Cup



Veribor blue line Suction Lifter, 2-Cup, Transverse Handle



Veribor blue line Suction Lifter, 2-Cup, Handle Lengthwise



德国工具系列



HUNTER 猎人牌黄胶锤

型号	产品明细	包装
2001/22	猎人牌黄胶锤 22mm	6
2002/27	猎人牌黄胶锤 27mm	6
2003/32	猎人牌黄胶锤 32mm	6
2004/35	猎人牌黄胶锤 35mm	6
2005/40	猎人牌黄胶锤 40mm	6
2006/50	猎人牌黄胶锤 50mm	6
2007/60	猎人牌黄胶锤 60mm	4
2401~2407	黄胶锤粒 22-60mm	2



HUNTER 猎人牌尼龙锤

型号	产品明细	包装
2101/22	猎人牌尼龙锤 22mm	6
2102/27	猎人牌尼龙锤 27mm	6
2103/32	猎人牌尼龙锤 32mm	6
2104/35	猎人牌尼龙锤 35mm	6
2105/40	猎人牌尼龙锤 40mm	6
2106/50	猎人牌尼龙锤 50mm	6
2107/60	猎人牌尼龙锤 60mm	4
2501~2507	尼龙锤粒 22-60mm	12



HUNTER 猎人牌钢字码A-Z+ &

型号	产品明细	包装
10101000	方型钢字码A-Z 1mm	10
10101500	方型钢字码A-Z 1.5mm	10
10102000	方型钢字码A-Z 2mm	10
10102500	方型钢字码A-Z 2.5mm	10
10103000	方型钢字码A-Z 3mm	10
10104000	方型钢字码A-Z 4mm	10
10105000	方型钢字码A-Z 5mm	10
10106000	方型钢字码A-Z 6mm	10
10108000	方型钢字码A-Z 8mm	10
10110000	方型钢字码A-Z 10mm	10
10112000	方型钢字码A-Z 12mm	10
10116000	方型钢字码A-Z 16mm	10
10120000	方型钢字码A-Z 20mm	10

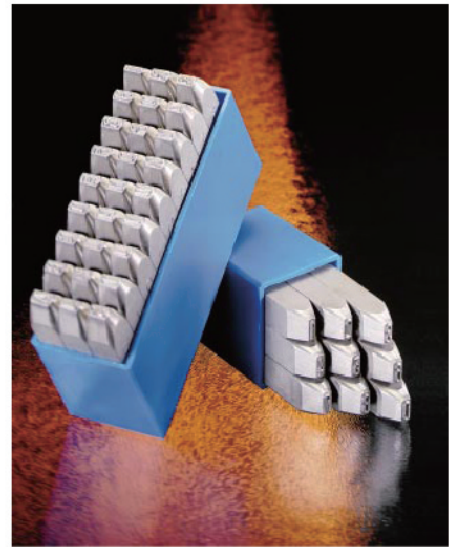

HUNTER 猎人牌钢字码0-9

型号	产品明细	包装
10001000	方型钢字码0-9 1mm	10
10001500	方型钢字码0-9 1.5mm	10
10002000	方型钢字码0-9 2mm	10
10002500	方型钢字码0-9 2.5mm	10
10003000	方型钢字码0-9 3mm	10
10004000	方型钢字码0-9 4mm	10
10005000	方型钢字码0-9 5mm	10
10006000	方型钢字码0-9 6mm	10
10008000	方型钢字码0-9 8mm	10
10010000	方型钢字码0-9 10mm	10
10012000	方型钢字码0-9 12mm	10
10016000	方型钢字码0-9 16mm	10
10020000	方型钢字码0-9 20mm	10



德国工具系列



HUNTER 猎人牌塞尺 (螺丝/固定头)

型号	产品明细	包装
100/7-13-100	猎人牌塞尺 13片 100mm 0.05-1.0	10
100/15-26-100	猎人牌塞尺 26片 100mm 0.03-1.0	10
100/7-13-150	猎人牌塞尺 13片 150mm 0.05-1.0	10
101/7-13-4"	猎人牌塞尺 13片 4" 2-35/1000"	10
202/6-20-150	猎人牌塞尺 20片 150mm 0.05-1.0	10
202/6-20-200	猎人牌塞尺 20片 200mm 0.05-1.0	10
202/6-20-300	猎人牌塞尺 20片 300mm 0.05-1.0	10
202/6-20-400	猎人牌塞尺 20片 400mm 0.05-1.0	10



HUNTER 猎人牌钢字片 0-9, A-Z

型号	产品明细	包装
2025	猎人牌钢字片 0-9 25mm	10
2050	猎人牌钢字片 0-9 50mm	10
2070	猎人牌钢字片 0-9 70mm	10
2100	猎人牌钢字片 0-9 100mm	10
2150	猎人牌钢字片 0-9 150mm	10
2200	猎人牌钢字片 0-9 200mm	10
3025	猎人牌钢字片 A-Z 25mm	10
3050	猎人牌钢字片 A-Z 50mm	10
3070	猎人牌钢字片 A-Z 70mm	10
3100	猎人牌钢字片 A-Z 100mm	10
3150	猎人牌钢字片 A-Z 150mm	10
3200	猎人牌钢字片 A-Z 200mm	10

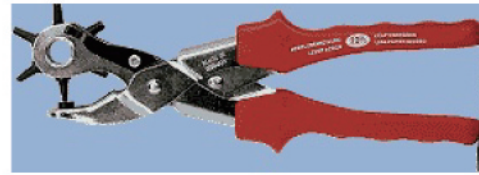

HUNTER 猎人牌专业打孔钳

型号	产品明细	包装
351a(B)b	金属柄磨光面 9"	10/100
370(B)npbh	红胶柄电镍面 10"	10/100



PRESSOL 专业黄油枪

型号	产品明细	容量
12632 482	高压黄油枪 (银色)	400cc
12632 951	高压黄油枪 (黑色)	400cc
12365	挤压式伸缩黄油枪	300cc

English pattern snips for long straight cuts

型号	产品明细
D159/200	English pattern Tin Snip 200mm - 8" without spring
D159/250	English pattern Tin Snip 250mm - 10" without spring
D159/300	English pattern Tin Snip 300mm - 12" without spring
D159/350	English pattern Tin Snip 350mm - 14" without spring
D159/250-F	English pattern Tin Snip 250mm - 10" without spring
D159/300-F	English pattern Tin Snip 300mm - 12" without spring
D159/350-F	English pattern Tin Snip 350mm - 14" without spring

红星牌

BRIGHT STAR

The first name in flashlights.SM



工业安全防爆灯具

WORKSAFE **LED** 系列

2224 LED

2217 LED

2206 LED



MODEL # 510304

100 Years of manufacturing innovative lighting products for everyday dependability



MADE IN USA

BRIGHT STAR

The first name in flashlights.SM



美国BRIGHTSTAR红星手电筒



WorkSAFE 工业安全防水手电筒 / LED

型号	产品明细	电池	小箱	大箱
2217	二芯安全手电筒	2XD (1号)	12	96
2224	三芯安全手电筒	2XD (1号)	12	96
2206	六伏电池安全提灯	1 X 6 伏	6	24

Responder 系列专业防水及消防灯具 / LED

型号	产品明细	电池	小箱	大箱
19101	三芯安全防水电筒	3XC (2号)	12	96
200201	二芯安全防水电筒	2XC (2号)	12	96
200301	二芯安全防水电筒	2XAA (3号)	12	96
19301	二芯安全防水电筒	2XAAA (4号)	12	96
500241	充电式曲头消防电筒	专用锂电	3	12
500304	四芯曲头消防电筒	4XC (2号)	6	24

UL - Underwriter Laboratories in Div 1 & 2 美国保险商实验所 地区一 及 地区二

CSA - Canadian Listing in Div 1 加拿大工业标准协会 地区一

MSHA - Mine Safety and Health Administration 美国矿山安全健康管理局

ATEX CE [EX " D "] in Category 2 Zone 1 欧盟成员标准

NFPA - National Fire Protection Association 国立防火组织



LIGHTHAWK 专业消防提灯 / LED

型号	产品明细	电池	灯泡	原箱
07810	充电消防提灯	110V 专用4芯锂电	黄色	3
07850	充电消防提灯	220V 专用4芯锂电	黄色	3
07855	充电消防提灯	220V 专用6芯锂电	黄色	3
07950	充电消防提灯	220V 专用4芯锂电	LED	3

RAZOR 工业安全电筒 (适用于 - 完全密封场地) / LED

型号	产品明细	电池	小箱	大箱
60100	冷光安全电筒 (黑色)	3XAA (3号)	12	96
60101	冷光安全电筒 (绿色)	3XAA (3号)	12	96
60102	冷光安全电筒 (橙色)	3XAA (3号)	12	96



DISSTON®

A Cut Above Since 1840

BLU-MOL®
BY DISSTON®

X BLU-MOL®
XTREME
BY DISSTON®

Aggressor®
BY DISSTON®

RemGrit®
BY DISSTON®



以色列



KAPRO®
TOOLS WITH VISION

嘉宝牌水平尺



最佳红色视觉水准泡
世界认可测量专家

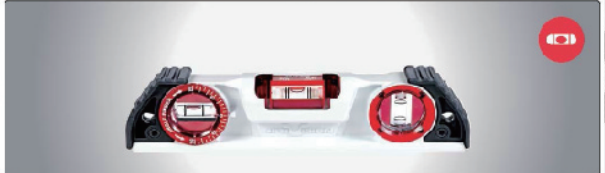

935 OPTIVISION™ Red Torpedo
10" (25cm) Magnetic Cast Aluminum Level



930 SmartCast with OPTIVISION™ Red
Heavy-Duty Mason's Level

888 PROLASER[®] VECTOR

3 Beam Self-Leveling Laser



895 PROLASER[®] ALL-LINES

7-Beam Self-Leveling Laser

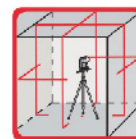

激光测距仪

370 PROLASER[®] KAPROMETER

Laser Distance Measurer

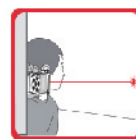

交叉激光基准仪

892 PROLASER[®] PLUS

Self-Leveling Cross-Beam Laser

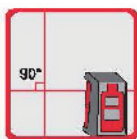

930 SMARTCAST[™] 压铸水平仪



935 OPTIVISION[™] 红视点鱼雷水平仪



325/352 活动角尺



781 GENESIS 专业盒装水平尺



779 SPRIT 建筑盒装水平尺



105 TOPGRADE 角度测量水平尺



985 DIG MAN 专业数显水平尺



920 SHARK 地台打击水平尺



227/923/724 迷你鱼雷水平尺



905 CONDOR 红视点水平尺



FISCH®Wave Cutter



Präzision. Qualität und Härte.

奥地利鱼唛
平底钻及钻咀系列



VIKING

丹麦维京
锯条系列

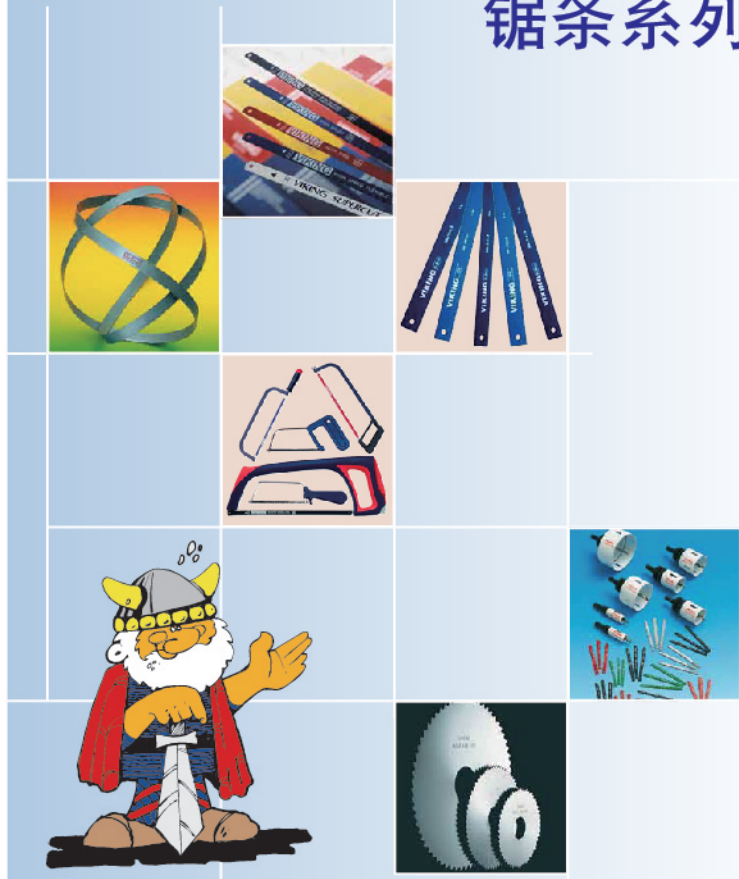

FLAG®

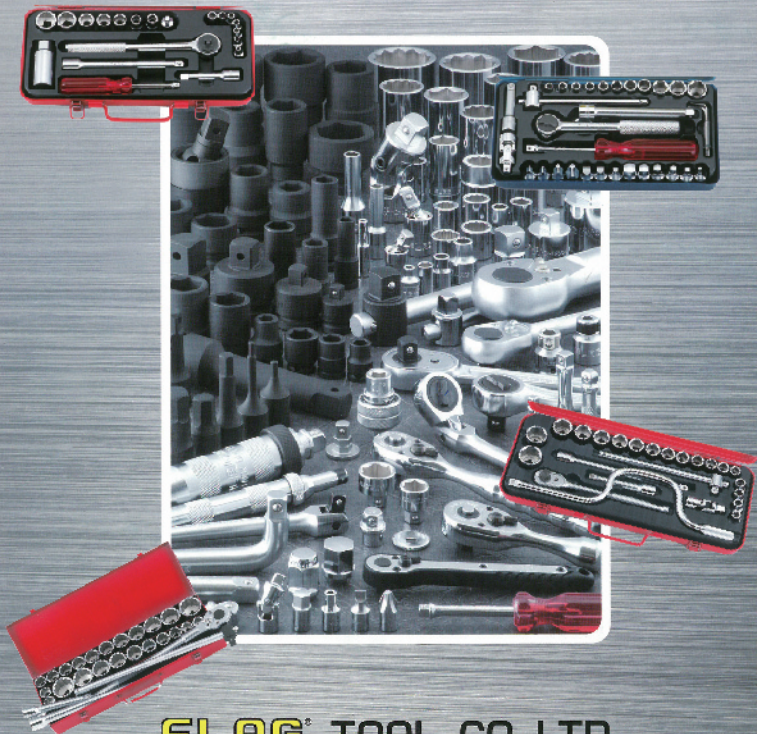

FLAG® TOOL CO.,LTD.



S Series

高性能绞盘，协助你完成各项艰辛的工作



美国进口强力绞盘



RENNSTEIG



OMI



世界名牌五金工具

LENT SERIES HEX KEY WRENCH

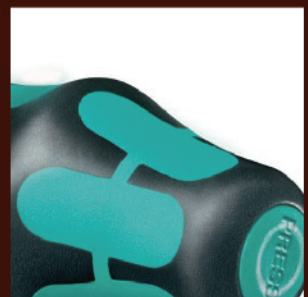
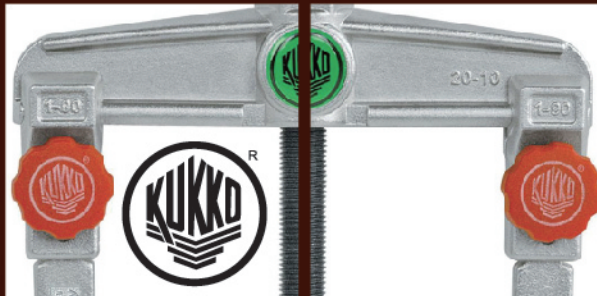
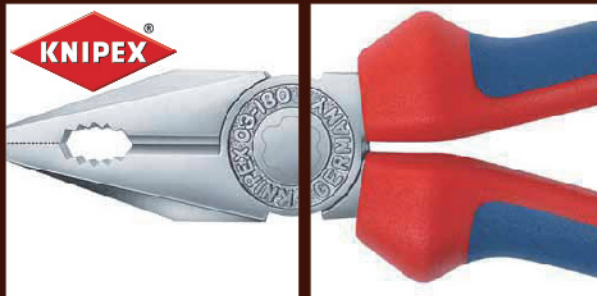

活动名称：
第二十九届中国
国际五金博览会

展会日期：
2016年
3月30日-4月1日

展会编号：
5.2馆T5-122(B)

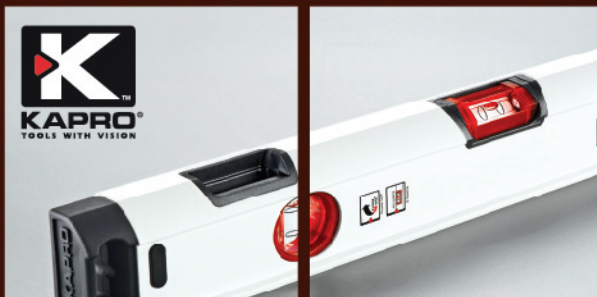

TUNG PO INTERNATIONAL LIMITED 通宝兆业有限公司

物料供应部：万国五金行

联络人：郑嘉煌先生 手机：(852) 9866 1447

电邮：ryan.c@tphtholdings.com

地址：香港弥敦道 563 号交通银行大厦 6 楼全层

电话：(852) 2543 3798 传真：(852) 2369 9681

电邮：sales@tphtholdings.com, tpil@biznetvigator.com

中国销售处：

SHENZHEN HING TAT COMPANY LIMITED

深圳市通宝兴达商贸发展有限公司

地址：深圳市罗湖区文锦北路文锦广场文安中心 2506 室

电话：(86) 755 2563 9008

传真：(86) 755 2563 9007

电邮：tbxdtools@126.com

网址：<http://www.tbxd.net.cn>

QQ: 93537010

联络人：梁少容小姐 电话：(86)189238 44639, 189234 61178